

Bellows materials

Standard temperature, natural rubber NR made with NR (natural), SBR (styrolbutadiene), BR (butadiene) elastomers, Carbon Black and Chemical products.

Natural rubber is an ideal material for industrial applications in or out door.

- Excellent universal properties
- Very high dynamic capability
- Elasticity
- Tensile strength
- Tear resistance
- Abrasion resistance
- For removable and Crimped air bellows types

NR

Air Bellows temperature ranges

	Static		Dynamic		-50	-40	-35	-30	-25	-20	0	+70	+90	+100	+115	+120	
	min (°C)	max (°C)	min (°C)	max (°C)													
Standard NR	-50	+90	-40	+70													

Air Bellows resistances

	NR
Abrasion	Yes
Anti freeze agents (ethylene glycol, glycerin)	Yes
Fuels	On request
Mineral or vegetable oils	On request
Silicone oil	Yes
Weak alkalis, soap solution	Yes
High concentration of ozone	On request
Inorganic acids < 10% and organic acids	Yes
Saline solutions, aqueous	Yes
Water	Yes

Bellows construction

Bellow rubber consists of:

An Outer & Inner covers rubbers

A first and second plies of reinforced rubber

An inside and outside cover rubber

These plies with cords are at a specific bias angle to one another.

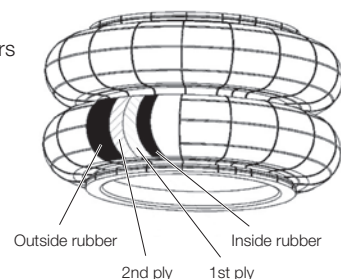

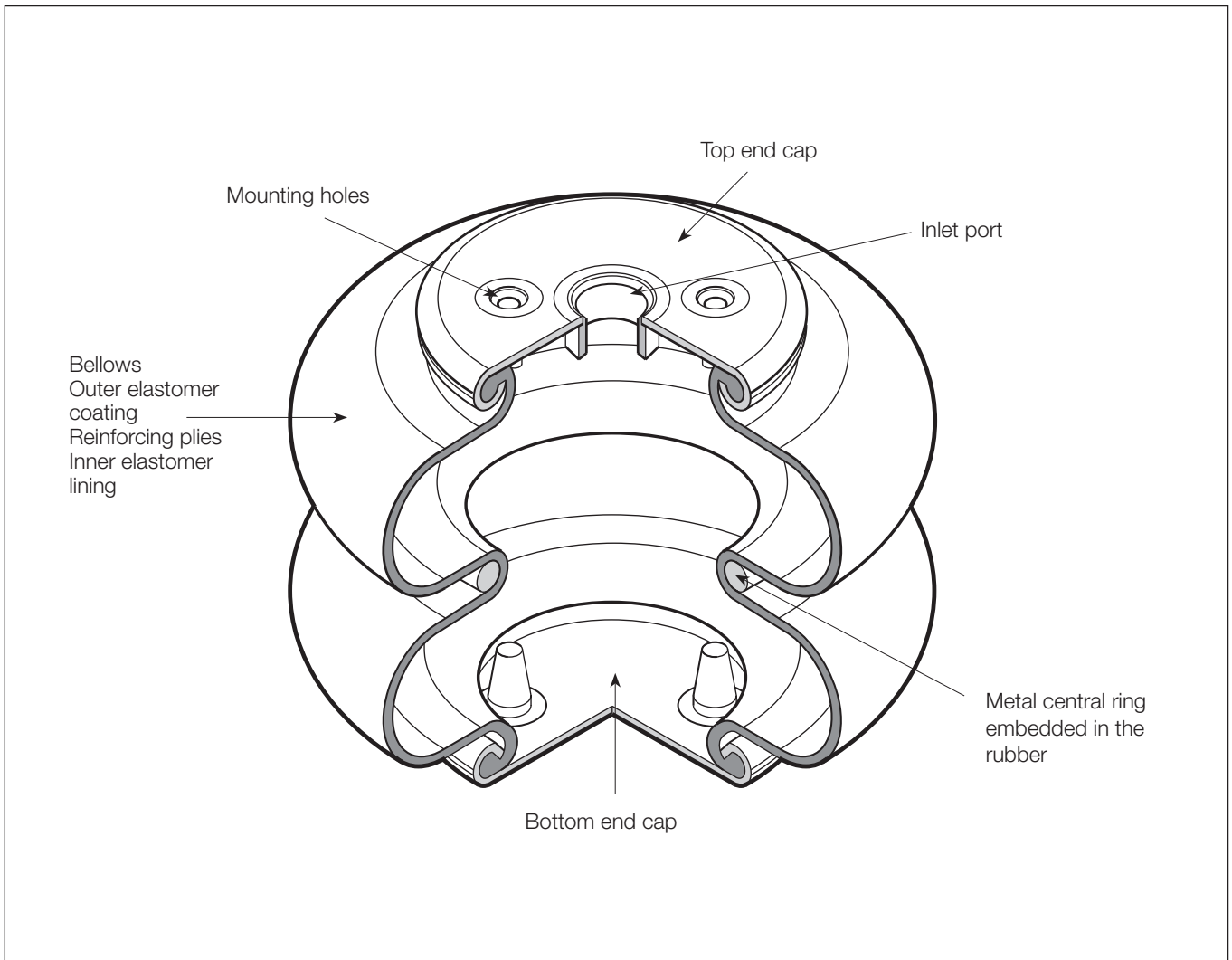

Crimped Convoluted Air Bellows

Air bellows are the ideal choice for applications requiring short stroke, high thrust single acting actuators.

Manufactured from fabric reinforced synthetic rubber in one or two convolutions according to stroke and model. They incorporate no reciprocating metal parts and so provide virtually frictionless thrust compared with conventional pneumatic cylinders.

All models are single acting only. The return stroke is provided in part by the natural spring action of the bellows but more usually by the load itself. The simplicity of construction provides an extremely long, virtually maintenance-free service life even under arduous conditions.

Air bellows are suitable for vibration applications i.e. device feeders at high frequency.

Versions

Air bellows are available with steel end plates.

Operation

Due to their flexible construction the mounting of Air Bellows is less critical than with conventional pneumatic cylinders, which normally require rigid fixing and guidance and provide only one axis within a limit of 30° between faces. Additionally the axial location of the end plates may be off set by up to 10 mm.

When pressurised Air Bellows will follow the line of least resistance. Accordingly care must be taken with the mounting geometry in angled applications.

When depressurised Air Bellows will fit in to surprisingly small spaces, especially useful for clamping or moving awkwardly shaped or very heavy loads.

In operation it is recommended that the unit is not allowed to "bottom out" or achieve its maximum height. Various mechanical devices may be employed to achieve this.

Technical specification, Crimped Air Bellows

- Single acting actuator
- One or two convolutions, three on request.

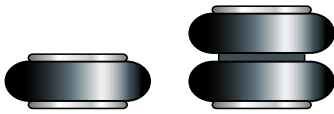

- The stroke is the difference between minimum and maximum heights. The force depends on the stroke.

Working pressure

- One air port on one end plate.
- Max static pressure 10 bar, working pressure 8 bar, 5.5 recommended for dynamic applications.
- Bursting pressure: 24 to 33 bar (depending on diameter, number of convolutions and type of elastomer).

Working medium, air quality

- Suitable for operation with compresses air or other gaseous media such as nitrogen.
- Also suitable for use with oil-free compressed air for the foodstuffs industry and in painting plants.
- Reliable even in low-pressure range with hydraulic media such as water or glycol.

Maintenance

- Free maintenance because no friction due to no part on movement. Non repairable, cups are crimped on the bellow.

Air Bellows material specification

Ø (mm)	Nb convolution	Type	End caps, clamping ring, central ring			Bellows *		
			Standard	Option stainless steel	Option Other treatment	Natural	Option chlorobutyl	Option epichlor
135	1 or 2	6 x 1 or 2	Steel DD13 zinc *	No	No	Compound NR-CBR	No	No
150	1 or 2	6.1/2 x 1 or 2						
155	2	7 x 2						
185	1	8 x 1						
220	1 or 2	10 x 1 or 2						
300	1 or 2	13 x 1 or 2						
350	1 or 2	16 x 1 or 2						

* Corrosion protection: Zinc alkaline / Passivation Chrome yellow 3 (Chrome free protection 6).

Resistance to salt spray > 480 hours rust red.

Conformity to ISO 1431-1 for ozone resistance.

Mountings on end plates

By internal threaded holes for

Ø 135 to 350 M8 12 Nm or M12 20 Nm

Clamping torques for screws

Ø 135 to 350 M8 12 Nm or M12 20 Nm



Recommendations



- It is not possible to combine angular misalignment with axial misalignment.
- It is imperative that external mechanical stops are used to limit the stroke.
- The units should not achieve maximum stroke or be allowed to "bottom out".
- Air Bellows may not be stacked, use singly only.
- The thrust of the Air Bellows depends on the height of the bellow.
- When height increases the thrust decreases because of the change in the effective area.
- DO NOT INFLATE the Air Bellow until it is not fixed on the machines with end stops. And so DEFLATE fully the Air Bellows before removing from the machine.
- Take care to put enough clearance around the Air Bellow because of the change in the section under pressure.
- Use the full surface of the end plates to bear the forces.
- Use guidance to avoid any angular or axial misalignments.

Part numbers for ordering, crimped convoluted Air Bellows

Ø (mm) (Inch size)	Type	Nb conv.	Air port size BSP	Weight (kg)	Max stroke (mm)	Cups material	Max force (N) at 7 bar	Order code			
								Standard cups		Stainless steel cups	
								Standard bellows	High temp bellows	Standard bellows	High temp bellows
135 (6")	6 x 1	1	G1/4	0,85	55	Steel	6850	KY9500	/	/	/
	6 x 2	2		1,00	110		7250	KY9612	/	/	/
150 (6.1/2")	6.1/2 x 1	1	G1/4	1,30	45	Steel	9140	KY8401	/	/	/
	6.1/2 x 2	2		1,50	80		9300	KY8011	/	/	/
155 (7")	7 x 1	1	G1/4	/	/	Steel	/	/	/	/	/
	7 x 2	2		1,60	105		9750	KY8012	/	/	/
185 (8")	8 x 1	1	G1/4	1,70	90	Steel	14270	KY9501	/	/	/
	8 x 2	2		2,00	125		14520	KY9589	/	/	/
220 (10")	10 x 1	1	G3/4	2,20	100	Steel	20780	KY9502	/	/	/
	10 x 2	2		2,70	150		21350	KY9611	/	/	/
300 (13")	13 x 1	1	G3/4	3,90	110	Steel	38770	KY9590	/	/	/
	13 x 2	2		4,60	170		38440	KY9591	/	/	/
350 (16")	16 x 1	1	G3/4	5,40	110	Steel	57220	KY8010	/	/	/
	16 x 2	2		6,20	170		59130	KY8007	/	/	/

Air Bellows permissible misalignments when Air Bellows are used as actuators

H rec. = recommended installation height | ØN min = minimum space diameter need for installing the Air Bellows

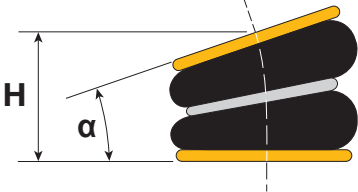
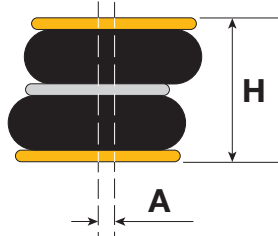
It is not possible to combine angular misalignment with axial misalignment.				Angular				Axial		
The following values are for short time movement during stroke. The Air Bellows may not be exposed to axial misalignment permanently.										
Ø (mm) (Inch size)	Order code	Type	Nb conv.	H rec. (mm)	Angle $\alpha = 5^\circ$ for H (mm) between min to max	Angle $\alpha = 10^\circ$ for H (mm) between min to max	Angle $\alpha = 15^\circ$ for H (mm) between min to max	ØN min (mm)	A = 5 mm for H (mm) between min to max	A = 10 mm for H (mm) between min to max
Ø 135 (6")	KY9500	6" x 1	1	95	55 to 95	60 to 90	Not adapted to	180	65 to 95	75 to 85
	KY9612	6" x 2	2	175	90 to 175	95 to 170	100 to 165	180	100 to 175	110 to 165
Ø 150 (6.1/2)	KY8401	6.1/2" x 1	1	85	60 to 85	65 to 80	Not adapted to	190	60 to 90	65 to 85
	KY8011	6.1/2" x 2	2	145	90 to 145	95 to 140	100 to 135	190	90 to 150	95 to 145
Ø 155 (7")	KY8012	7" x 2	2	170	90 to 170	95 to 165	100 to 160	205	90 to 175	95 to 165
Ø 185 (8")	KY9501	8" x 1	1	115	60 to 115	65 to 110	70 to 105	230	70 to 120	80 to 115
	KY9589	8" x 2	2	200	105 to 200	115 to 195	120 to 190	230	100 to 205	105 to 195
Ø 220 (10")	KY9502	10" x 1	1	135	60 to 135	70 to 125	75 to 120	270	65 to 145	70 to 135
	KY9611	10" x 2	2	215	105 to 220	110 to 210	120 to 205	270	105 to 225	115 to 215
Ø 300 (13")	KY9590	13" x 1	1	150	75 to 150	85 to 140	95 to 130	340	70 to 135	80 to 130
	KY9591	13" x 2	2	230	105 to 235	115 to 225	125 to 215	340	110 to 240	115 to 230
Ø 350 (16")	KY8010	16" x 1	1	150	80 to 145	90 to 135	100 to 125	400	75 to 140	85 to 135
	KY8007	16" x 2	2	230	110 to 235	120 to 220	135 to 210	400	115 to 235	120 to 230

Vibration isolation (damping) when Air Bellows are used as isolators

The stiffness is the reaction force that appears when Air Bellow deflects from its initial position.

Due to the compression of air the stiffness is not constant as it is a function of effective area variation, volume and pressure variations.

H2 rec. = recommended installation height for best isolation.

Isolation rate I (%) fe=exciting frequency (Hz) fn=natural frequency (Hz)							At 2 bar		At 4 bar		At 6 bar		At 0 bar		
Ø (mm) (Inch size)	Order code	Type	Nb conv.	Max stroke (mm)	Static height (mm)	H2 rec. (mm)	I = 1 - $\frac{1}{\left(\frac{f_e}{f_n}\right)^2 - 1}$		Natural Frequency fn (Hz)	Stiffness (daN/cm)	Natural Frequency fn (Hz)	Stiffness (daN/cm)	Natural Frequency fn (Hz)	Stiffness (daN/cm)	Load (N) to obtain H min
							Natural Frequency fn (Hz)	Stiffness (daN/cm)							
Ø 135 (6")	KY9500	6 x 1	1	55	80	75	3,14	7	3,1	11,56	3,07	18,02	15		
	KY9612	6 x 2	2	110	135	135	2,39	4,17	2,34	6,63	2,3	10,22	25		
Ø 150 (6.1/2")	KY8401	6.1/2 x 1	1	45	75	70	4,12	13,38	4,1	26,84	4,04	41,5	110		
	KY8011	6.1/2 x 2	2	80	120	120	2,72	5,98	2,66	12,27	2,64	18	80		
Ø 155 (7")	KY8012	7 x 2	2	105	125	130	2,53	5,8	2,47	11,06	2,43	16,41	100		
Ø 185 (8")	KY9501	8 x 1	1	80	90	90	2,87	9,74	2,81	18,83	2,78	28,95	50		
	KY9589	8 x 2	2	125	160	160	2,14	5,42	2,07	10,14	2,03	15,11	30		
Ø 220 (10")	KY9502	10 x 1	1	100	100	100	2,42	11,54	2,37	22,81	2,33	34,25	50		
	KY9611	10 x 2	2	150	165	165	1,89	7,04	1,83	14,39	1,8	20,69	60		
Ø 300 (13")	KY9590	13 x 1	1	110	115	115	2,13	17,89	2,09	34,44	2,05	51,36	150		
	KY9591	13 x 2	2	170	175	175	1,75	11,23	1,71	21,33	1,67	29,69	100		
Ø 350 (16")	KY8010	16 x 1	1	110	115	115	2,11	28,08	2,07	54,06	2,04	77,11	80		
	KY8007	16 x 2	2	170	175	175	1,88	20,2	1,85	39,13	1,83	58,09	100		

Air Bellows mounting dimensions (mm), crimped type

H min, H max = recommended installation heights

H rec. = height recommended when air bellows is used as an actuator

H2 rec. = height recommended when air bellows is used as an isolator

F = thread depth for fixing

ØN min = minimum space diameter need for installing the air bellows



It is imperative that external mechanical end stops are used to limit the stroke. The air bellows should not achieve maximum or minimum heights or be allowed to "bottom out". Air bellows may not be stacked, use singly only.

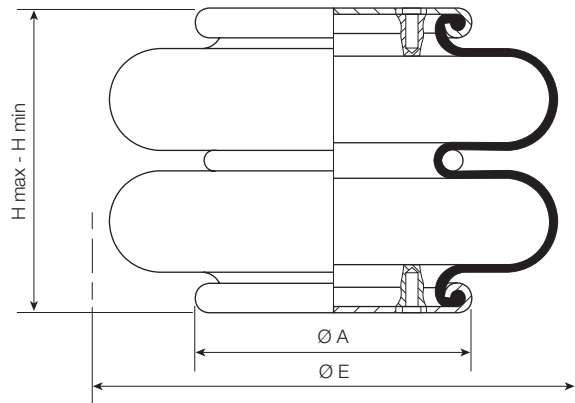

Air Bellows description				Material	Weight	Height						Diameters			
Ø (mm) (Inch size)	Order code	Type	Nb conv.	Cup material	Kg	Max stroke mm	H min mm	H static mm	H max mm	H rec. mm	H2 rec. mm	ØA mm	ØE static mm	ØE max mm	ØN min mm
Ø135 (6")	KY9500	6" x 1	1	Steel	0,85	55	50	80	105	95	75	91	135	145	180
	KY9612	6" x 2	2	Steel	1,00	110	80	135	190	175	135	91	135	150	180
Ø150 (6.1/2")	KY8401	6.1/2" x 1	1	Steel	1,30	45	50	75	95	85	70	112	150	165	190
	KY8011	6.1/2" x 2	2	Steel	1,50	80	80	120	160	145	120	112	150	165	190
Ø155 (7")	/	7" x 1	1	Steel	/	/	/	/	/	/	/	/	/	/	/
	KY8012	7" x 2	2	Steel	1,60	105	80	125	185	170	130	112	155	160	205
Ø185 (8")	KY9501	8" x 1	1	Steel	1,70	80	50	90	130	115	90	136	185	200	230
	KY9589	8" x 2	2	Steel	2,00	125	95	160	220	200	160	136	185	200	230
Ø220 (10")	KY9502	10" x 1	1	Steel	2,20	100	50	100	150	135	100	160	220	240	270
	KY9611	10" x 2	2	Steel	2,70	150	90	165	240	215	165	160	220	240	270
Ø300 (13")	KY9590	13" x 1	1	Steel	3,90	110	60	115	170	150	115	228	300	325	340
	KY9591	13" x 2	2	Steel	4,60	170	90	175	260	230	175	228	300	330	340
Ø350 (16")	KY8010	16" x 1	1	Steel	5,40	110	60	115	170	150	115	288	350	370	400
	KY8007	16" x 2	2	Steel	6,20	170	90	175	260	230	175	288	350	370	400

Air Bellows description			Mounting *					Pressure			
Ø (mm) (Inch size)	Order code	Type	J mm	H mm	K mm	L mm	G mm	Air port	Max static bar	Max dyn. bar	Rec. dyn. bar
Ø135 (6")	KY9500	6" x 1	9,0	22,0	11,0	-	M8 depth 15	G1/4	10	8	5,5
	KY9612	6" x 2									
Ø150 (6.1/2")	KY8401	6.1/2" x 1	-	44,5	-	-	M8 depth 15	G1/4	10	8	5,5
	KY8011	6.1/2" x 2									
Ø155 (7")	/	7" x 1	/	/	/	/	/	/	/	/	/
	KY8012	7" x 2	-	44,5	-	-	M8 depth 15	G1/4	10	8	5,5
Ø185 (8")	KY9501	8" x 1	-	54,0	-	27,0	M8 depth 15	G1/4	10	8	5,5
	KY9589	8" x 2									
Ø220 (10")	KY9502	10" x 1	-	89,0	-	38,0	M8 depth 15	G3/4	10	8	5,5
	KY9611	10" x 2									
Ø300 (13")	KY9590	13" x 1	-	157,5	-	73,0	M12 depth 22	G3/4	10	8	5,5
	KY9591	13" x 2									
Ø350 (16")	KY8010	16" x 1	-	158,8	-	-	M8 depth 15	G3/4	10	8	5,5
	KY8007	16" x 2									

* For endplate mounting and air port dimensions see following pages.

Note: Depending on the production some non functional dimensions could differ, for more detail please consult the factory.

Type x Number of Convolution: **6" x 1, Ø 135**

Adiabatic characteristic curves / Dynamic movements

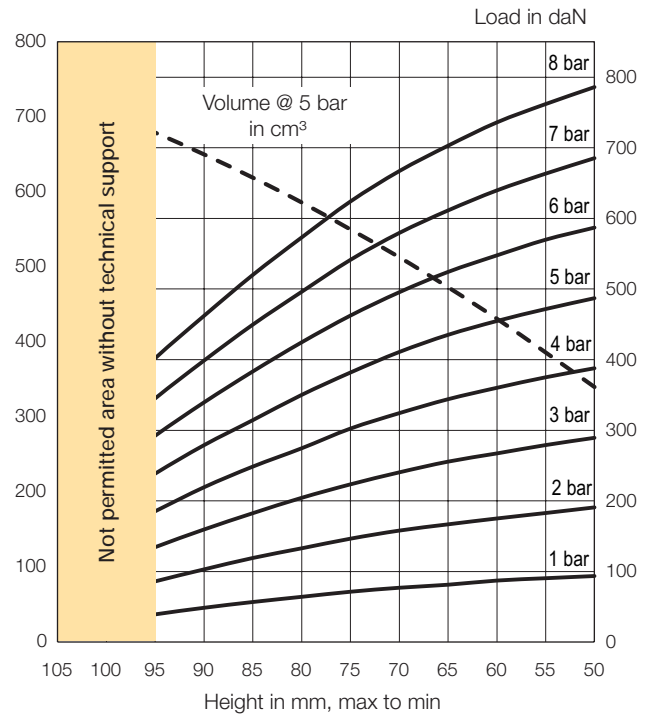
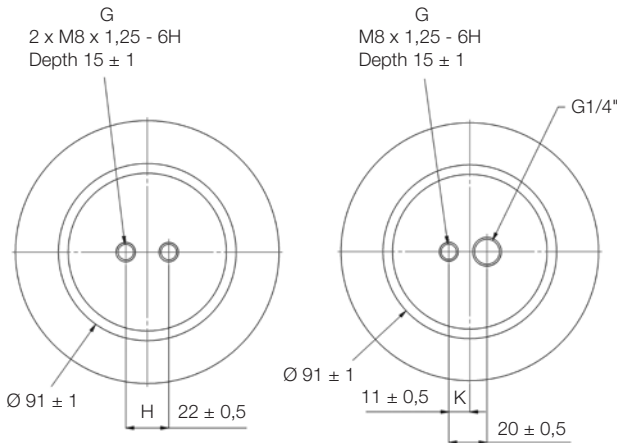

Order Code

Materials	Cups	Standard cups	Stainless steel cups
Standard temperature		KY9500	-
High temperature CR	Steel	-	-
Extreme high temp. ECO		-	-

Technical data

Air port inlet	G1/4
Rec / Max pressure [bar]	5,5 / 8
Force to Hmin @ 0 bar [N]	15
Weight [kg]	0,85

Dimensions [mm]

Ø maxi.	145
Øe	180
H static	80
H min.	50
H max.	105
H recommended	95

Fastening torque [Nm]

G1/4	15
M8	12

Dynamic characteristic values

Pressure p [bar]	2	4	6
Stiffness [daN/cm]	7,0	11,6	18,0
Natural frequency [Hz]	3,14	3,10	3,07
H2 rec for isolation [mm]	75		

Misalignment for H between [mm]

Axial	A = 5 mm	65 to 95
	A = 10 mm	75 to 85
Angular	Angle α = 5°	55 to 95
	Angle α = 10°	60 to 90
	Angle α = 15°	-

Static characteristic values

Pressure p [bar]	Force F [daN]							Vol. V [cm³]
	3	4	5	6	7	8		
Height H [mm]	50	289	388	487	587	685	786	340
	60	267	360	455	548	640	736	431
	70	240	324	411	495	579	667	513
	80	204	274	350	424	496	573	586
	90	159	219	279	339	399	462	650
	100	108	151	194	241	286	335	706
	105	77	111	148	184	222	263	730

Type x Number of Convolution: **6.1/2" x 1, Ø 150**

Adiabatic characteristic curves / Dynamic movements

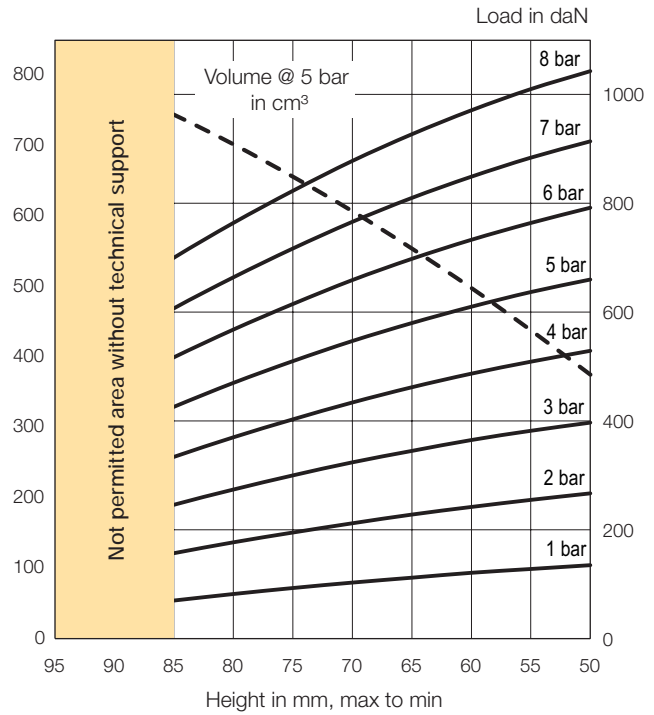
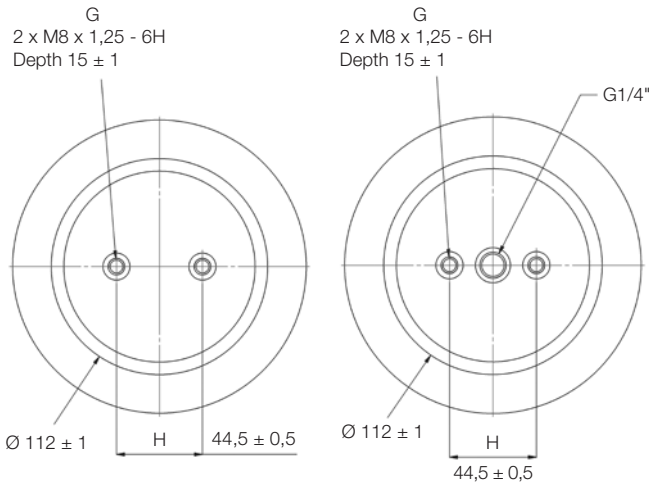

Order Code

Materials	Cups	Standard cups	Stainless steel cups
Standard temperature		KY8401	-
High temperature CR	Steel	-	-
Extreme high temp. ECO		-	-

Technical data

Air port inlet	G1/4"
Rec / Max pressure [bar]	5,5 / 8
Force to Hmin @ 0 bar [N]	110
Weight [kg]	1,30

Dimensions [mm]

Ø maxi.	160
Øe	190
H static	75
H min.	50
H max.	95
H recommended	85

Fastening torque [Nm]

G1/4"	15
M8	12

Dynamic characteristic values

Pressure p [bar]	2	4	6
Stiffness [daN/cm]	13,4	26,8	41,5
Natural frequency [Hz]	4,1	4,1	4,0
H2 rec for isolation [mm]		70	

Misalignment for H between [mm]

Axial	A = 5 mm	60 to 90
	A = 10 mm	65 to 85
Angular	Angle α = 5°	60 to 85
	Angle α = 10°	65 to 80
	Angle α = 15°	-

Static characteristic values

Pressure p [bar]	Force F [daN]						Vol. V [cm³]	
	3	4	5	6	7	8		
Height H [mm]	50	397	529	660	792	914	1043	375
	60	365	487	610	733	849	971	498
	70	324	434	547	659	766	878	607
	80	274	370	470	568	664	764	702
	85	246	334	426	517	607	700	744
	90	215	296	379	462	544	630	782
	95	183	255	328	403	478	555	818

Type x Number of Convolution: **8" x 1, Ø 185**

Adiabatic characteristic curves / Dynamic movements

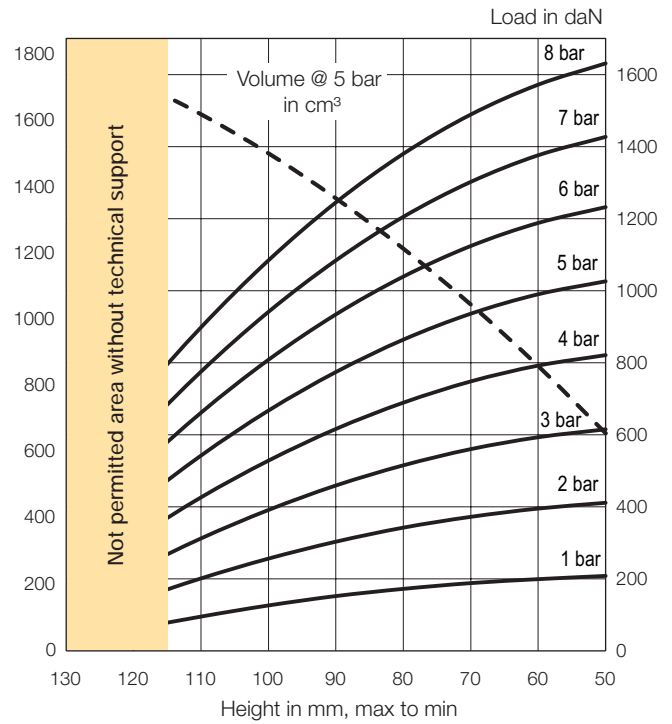
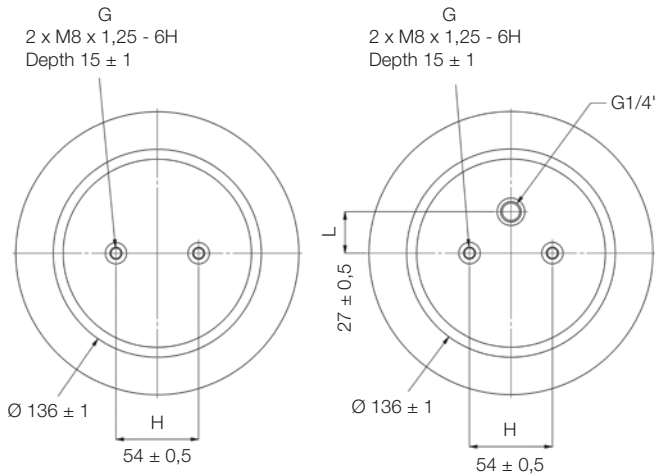

Order Code

Materials	Cups	Standard cups	Stainless steel cups
Standard temperature		KY9501	-
High temperature CR	Steel	-	-
Extreme high temp. ECO		-	-

Technical data

Air port inlet	G1/4"
Rec / Max pressure [bar]	5,5 / 8
Force to Hmin @ 0 bar [N]	50
Weight [kg]	1,70

Dimensions [mm]

Ø maxi.	200
Øe	230
H static	90
H min.	50
H max.	130
H recommended	115

Fastening torque [Nm]

G1/4"	15
M8	12

Dynamic characteristic values

Pressure p [bar]	2	4	6
Stiffness [daN/cm]	9,7	18,8	29,0
Natural frequency [Hz]	2,9	2,8	2,8
H2 rec for isolation [mm]	90		

Misalignment for H between [mm]

Axial	A = 5 mm	70 to 120
	A = 10 mm	80 to 115
Angular	Angle α = 5°	60 to 115
	Angle α = 10°	65 to 110
	Angle α = 15°	70 to 105

Static characteristic values

Pressure p [bar]	Force F [daN]							Vol. V [cm³]
	3	4	5	6	7	8		
50	615	821	1026	1232	1427	1631	657	
70	560	748	936	1124	1302	1489	1046	
90	459	616	774	934	1084	1245	1367	
110	312	426	542	661	775	898	1621	
130	118	176	239	305	373	449	1808	
-	-	-	-	-	-	-	-	
-	-	-	-	-	-	-	-	

Type x Number of Convolution: **10" x 1, Ø 220**

Adiabatic characteristic curves / Dynamic movements

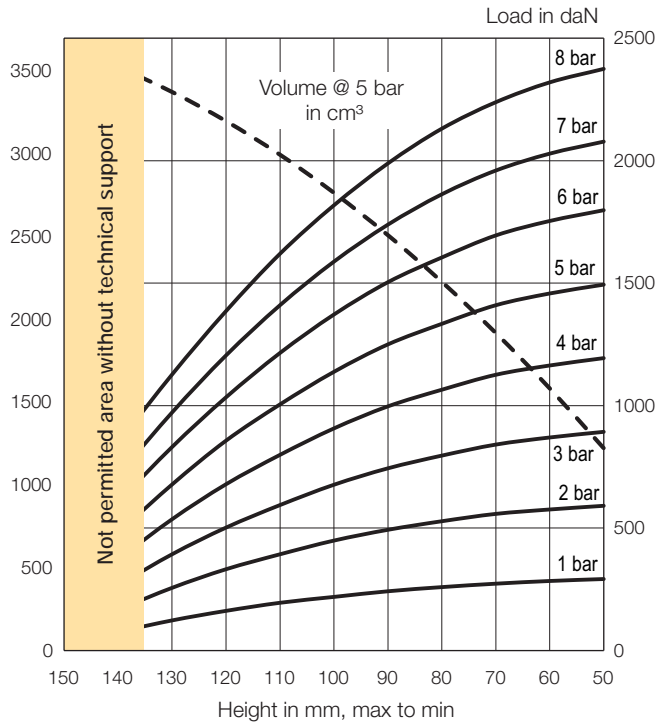
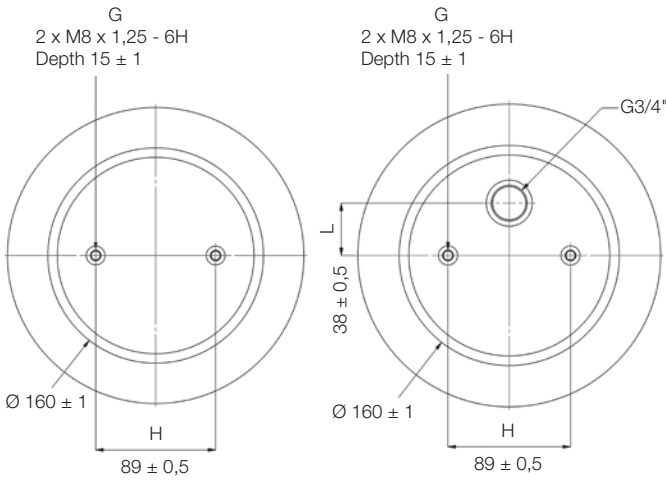

Order Code

Materials	Cups	Standard cups	Stainless steel cups
Standard temperature		KY9502	-
High temperature CR	Steel	-	-
Extreme high temp. ECO		-	-

Technical data

Air port inlet	G3/4"
Rec / Max pressure [bar]	5,5 / 8
Force to Hmin @ 0 bar [N]	50
Weight [kg]	2,20

Dimensions [mm]

Ø maxi.	240
Øe	270
H static	100
H min.	50
H max.	150
H recommended	135

Fastening torque [Nm]

G3/4"	50
M8	12

Dynamic characteristic values

Pressure p [bar]	2	4	6
Stiffness [daN/cm]	11,5	22,8	34,3
Natural frequency [Hz]	2,4	2,4	2,3
H2 rec for isolation [mm]		100	

Misalignment for H between [mm]

Axial	A = 5 mm	65 to 145
	A = 10 mm	70 to 135
Angular	Angle α = 5°	60 to 135
	Angle α = 10°	70 to 125
	Angle α = 15°	75 to 120

Static characteristic values

Pressure p [bar]	Force F [daN]						Vol. V [cm³]
	3	4	5	6	7	8	
50	893	1194	1494	1798	2078	2375	1224
70	841	1126	1410	1695	1960	2239	1920
90	744	997	1250	1504	1739	1989	2511
110	594	799	1005	1215	1410	1620	2997
130	393	536	678	831	972	1127	3376
150	114	179	254	331	414	510	3650
-	-	-	-	-	-	-	-

Type x Number of Convolution: **13" x 1, Ø 300**

Adiabatic characteristic curves / Dynamic movements

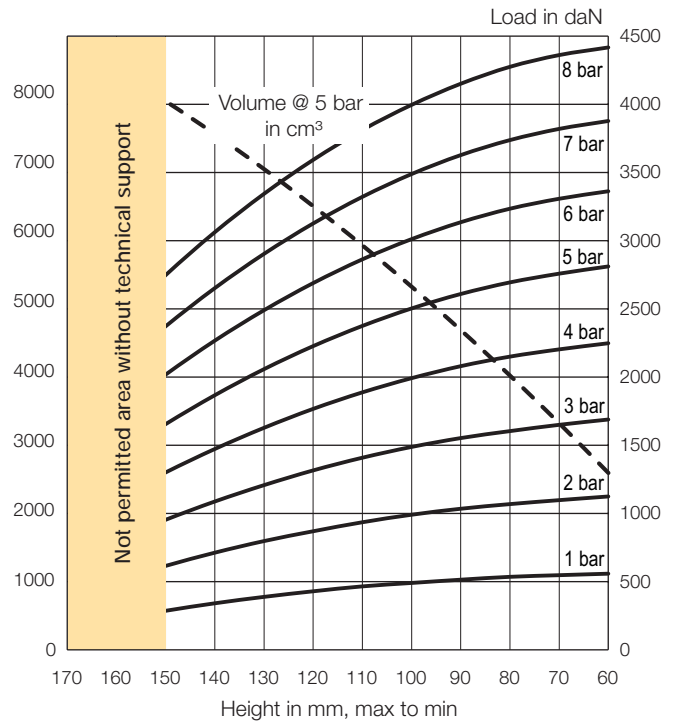
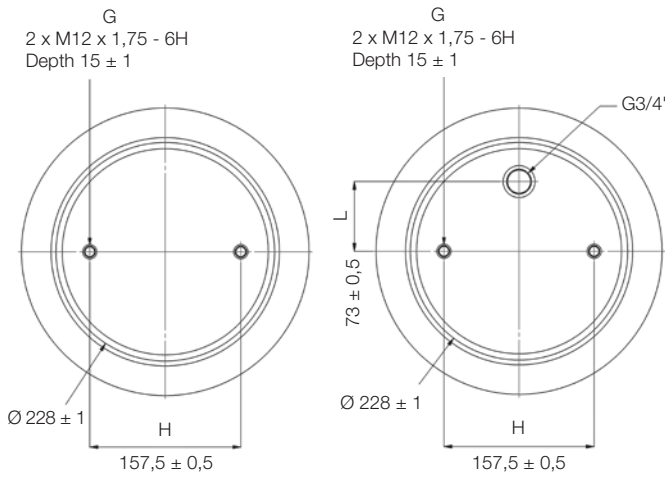

Order Code

Materials	Cups	Standard cups	Stainless steel cups
Standard temperature		KY9590	-
High temperature CR	Steel	-	-
Extreme high temp. ECO		-	-

Technical data

Air port inlet	G3/4"
Rec / Max pressure [bar]	5,5 / 8
Force to Hmin @ 0 bar [N]	150
Weight [kg]	3,90

Dimensions [mm]

Ø maxi.	325
Øe	340
H static	115
H min.	60
H max.	170
H recommended	150

Fastening torque [Nm]

G3/4"	50
M12	20



Dynamic characteristic values

Pressure p [bar]	2	4	6
Stiffness [daN/cm]	17,9	34,4	51,4
Natural frequency [Hz]	2,1	2,1	2,1
H2 rec for isolation [mm]	115		

Misalignment for H between [mm]

Axial	A = 5 mm	70 to 135
	A = 10 mm	80 to 130
Angular	Angle α = 5°	75 to 150
	Angle α = 10°	85 to 140
	Angle α = 15°	95 to 130

Static characteristic values

Pressure p [bar]	Force F [daN]						Vol. V [cm³]
	3	4	5	6	7	8	
60	1689	2248	2811	3362	3877	4416	2538
80	1604	2150	2694	3234	3737	4274	3933
100	1488	1992	2503	3011	3488	3995	5207
120	1316	1767	2227	2689	3126	3592	6361
140	1088	1473	1867	2267	2652	3062	7394
160	807	1111	1423	1745	2064	2400	8308
170	639	895	1164	1444	1728	2027	8719

Type x Number of Convolution: **16" x 1, Ø 350**

Adiabatic characteristic curves / Dynamic movements

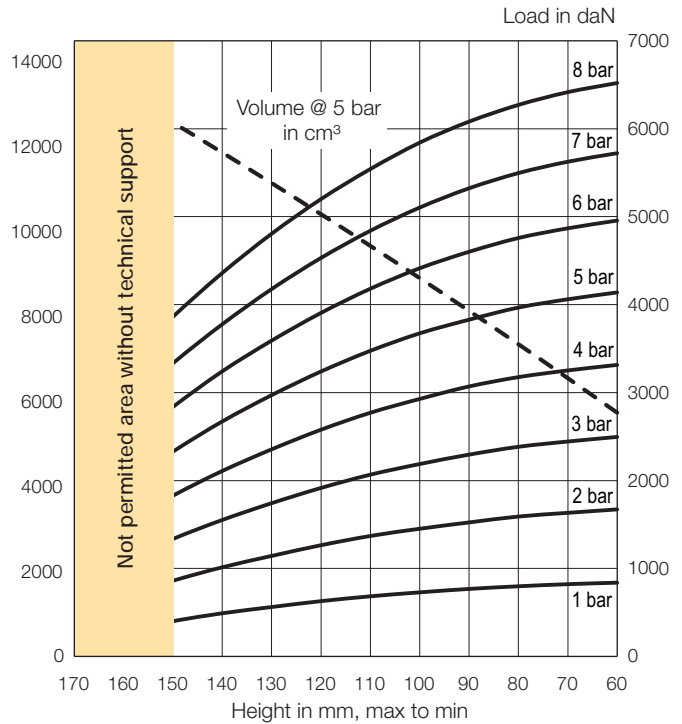
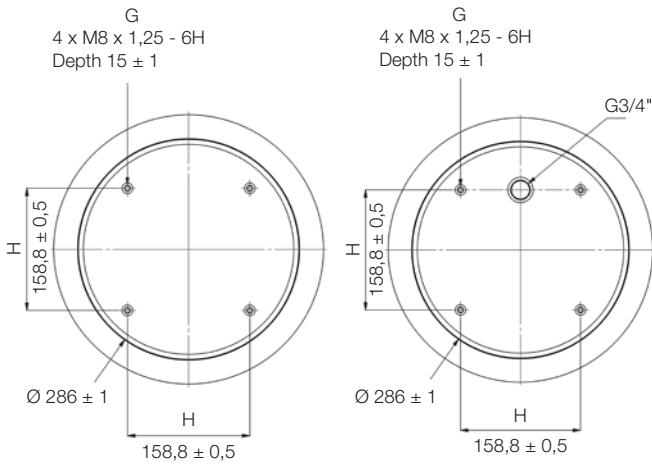

Order Code

Materials	Cups	Standard cups	Stainless steel cups
Standard temperature		KY8010	-
High temperature CR	Steel	-	-
Extreme high temp. ECO		-	-

Technical data

Air port inlet	G3/4"
Rec / Max pressure [bar]	5,5 / 8
Force to Hmin @ 0 bar [N]	80
Weight [kg]	5,40

Dimensions [mm]

Ø maxi.	370
Øe	400
H static	115
H min.	60
H max.	170
H recommended	150

Fastening torque [Nm]

G3/4"	50
M8	12

Dynamic characteristic values

Pressure p [bar]	2	4	6
Stiffness [daN/cm]	28,1	54,1	77,1
Natural frequency [Hz]	2,1	2,1	2,0
H2 rec for isolation [mm]	115		

Misalignment for H between [mm]

Axial	A = 5 mm	75 to 140
	A = 10 mm	85 to 135
Angular	Angle α = 5°	80 to 145
	Angle α = 10°	90 to 135
	Angle α = 15°	100 to 125

Static characteristic values

Pressure p [bar]	Force F [daN]						Vol. V [cm³]
	3	4	5	6	7	8	
60	2496	3315	4139	4956	5722	6520	5743
80	2384	3176	3967	4758	5496	6271	7354
100	2188	2928	3674	4414	5104	5842	8911
120	1916	2578	3240	3906	4531	5200	10415
140	1552	2109	2672	3242	3777	4360	11866
160	1087	1512	1950	2399	2843	3322	13264
170	808	1148	1511	1901	2302	2729	13943

Type x Number of Convolution: **6" x 2, Ø 135**

Adiabatic characteristic curves / Dynamic movements

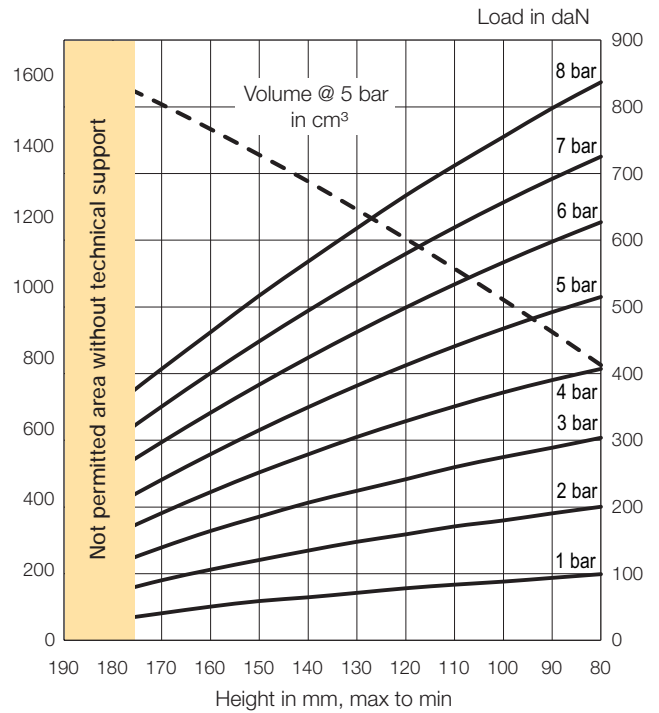
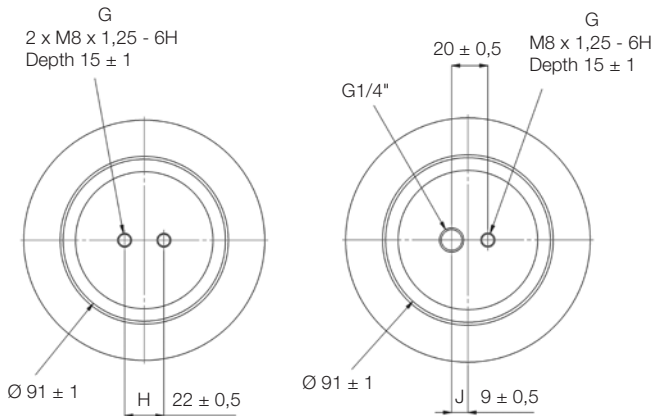

Order Code

Materials	Cups	Standard cups	Stainless steel cups
Standard temperature		KY9612	-
High temperature CR	Steel	-	-
Extreme high temp. ECO		-	-

Technical data

Air port inlet	G1/4"
Rec / Max pressure [bar]	5,5 / 8
Force to Hmin @ 0 bar [N]	25
Weight [kg]	1,00

Dimensions [mm]

Ø maxi.	150
Øe	180
H static	135
H min.	80
H max.	190
H recommended	175

Fastening torque [Nm]

G1/4"	15
M8	12



Dynamic characteristic values

Pressure p [bar]	2	4	6
Stiffness [daN/cm]	4,2	6,6	10,2
Natural frequency [Hz]	2,39	2,34	2,30
H2 rec for isolation [mm]	135		

Misalignment for H between [mm]

Axial	A = 5 mm	100 to 175
	A = 10 mm	110 to 165
Angular	Angle α = 5°	90 to 175
	Angle α = 10°	95 to 170
	Angle α = 15°	100 to 165

Static characteristic values

Pressure p [bar]	Force F [daN]							Vol. V [cm³]
	3	4	5	6	7	8		
80	304	407	515	627	725	837	780	
100	275	372	468	567	657	755	965	
120	242	329	412	499	580	667	1138	
140	206	279	350	424	494	568	1300	
160	164	222	279	341	401	462	1448	
180	112	157	201	251	299	350	1584	
190	83	122	159	203	244	292	1650	

Type x Number of Convolution: **6.1/2" x 2, Ø 150**

Adiabatic characteristic curves / Dynamic movements

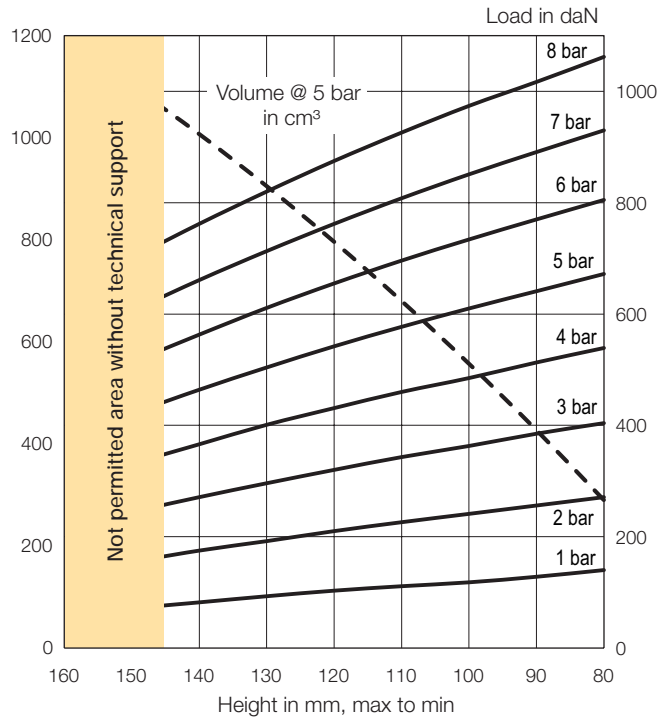
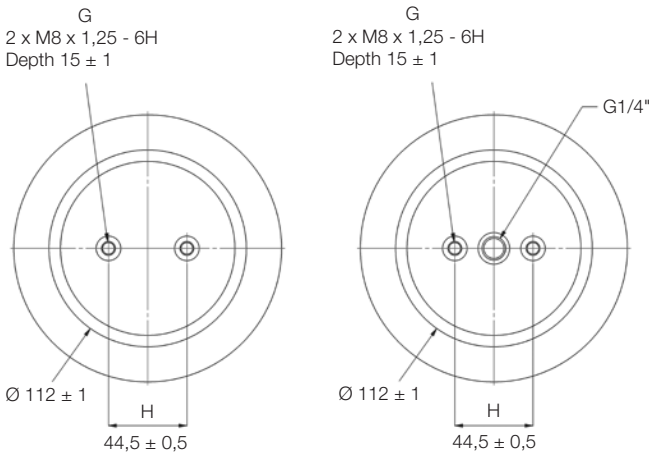

Order Code

Materials	Cups	Standard cups	Stainless steel cups
Standard temperature		KY8011	-
High temperature CR	Steel	-	-
Extreme high temp. ECO		-	-

Technical data

Air port inlet	G1/4"
Rec / Max pressure [bar]	5,5 / 8
Force to Hmin @ 0 bar [N]	80
Weight [kg]	1,50

Dimensions [mm]

Ø maxi.	160
Øe	190
H static	120
H min.	80
H max.	160
H recommended	145

Fastening torque [Nm]

G1/4"	15
M8	12

Dynamic characteristic values

Pressure p [bar]	2	4	6
Stiffness [daN/cm]	6,0	12,3	18,0
Natural frequency [Hz]	2,7	2,7	2,6
H2 rec for isolation [mm]		120	

Misalignment for H between [mm]

Axial	A = 5 mm	90 to 150
	A = 10 mm	95 to 145
Angular	Angle α = 5°	90 to 145
	Angle α = 10°	95 to 140
	Angle α = 15°	100 to 135

Static characteristic values

Pressure p [bar]	Force F [daN]						Vol. V [cm³]
	3	4	5	6	7	8	
80	404	539	672	805	930	1062	290
100	363	485	610	734	851	974	557
120	320	431	542	655	762	875	796
140	271	366	464	563	661	762	1007
150	244	331	421	513	605	700	1101
160	213	294	377	460	546	633	1189
-	-	-	-	-	-	-	-

Type x Number of Convolution: **7" x 2, Ø 155**

Adiabatic characteristic curves / Dynamic movements

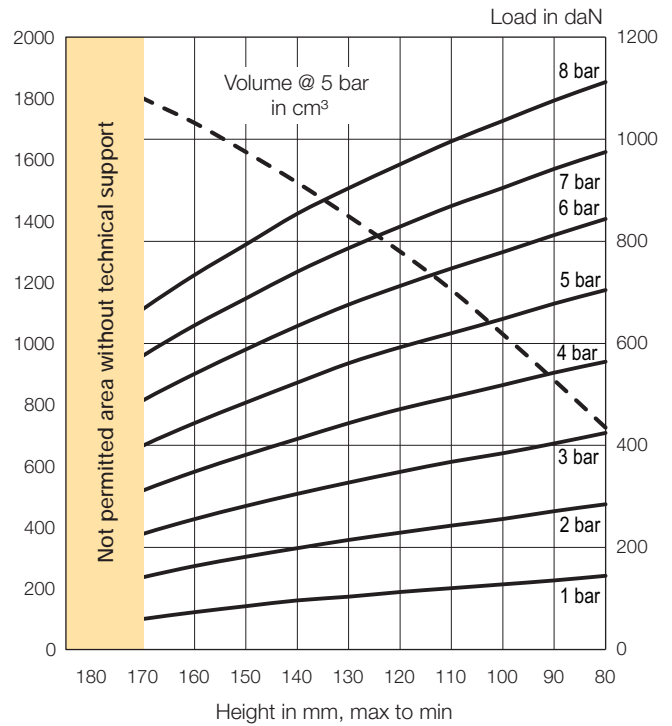
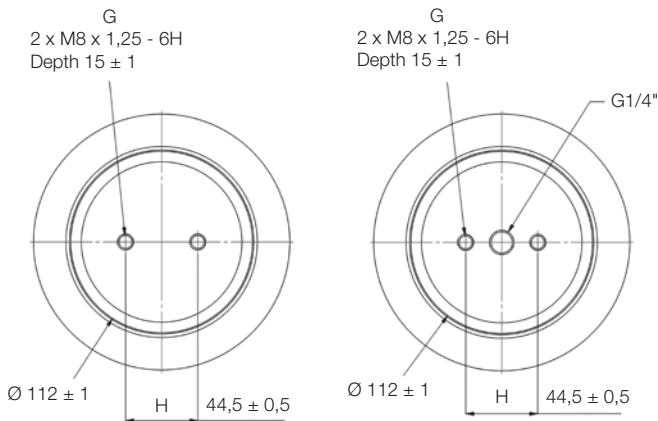

Order Code

Materials	Cups	Standard cups	Stainless steel cups
Standard temperature		KY8012	-
High temperature CR	Steel	-	-
Extreme high temp. ECO		-	-

Technical data

Air port inlet	G1/4
Rec / Max pressure [bar]	5,5 / 8
Force to Hmin @ 0 bar [N]	100
Weight [kg]	1,60

Dimensions [mm]

Ø maxi.	160
Øe	205
H static	125
H min.	80
H max.	185
H recommended	170

Fastening torque [Nm]

G1/4"	15
M8	12

Dynamic characteristic values

Pressure p [bar]	2	4	6
Stiffness [daN/cm]	5,8	11,1	16,4
Natural frequency [Hz]	2,5	2,5	2,4
H2 rec for isolation [mm]	130		

Misalignment for H between [mm]

Axial	A = 5 mm	90 to 175
	A = 10 mm	95 to 165
Angular	Angle α = 5°	90 to 170
	Angle α = 10°	95 to 165
	Angle α = 15°	100 to 160

Static characteristic values

Pressure p [bar]	Force F [daN]							Vol. V [cm³]
	3	4	5	6	7	8		
80	424	564	704	844	975	1112	725	
100	385	518	648	779	905	1036	1030	
120	348	471	592	712	829	951	1300	
140	305	413	523	634	740	854	1525	
150	281	382	484	588	688	794	1625	
160	255	348	444	540	635	734	1720	
170	227	312	400	488	576	667	1800	

Type x Number of Convolution: **8" x 2, Ø 185**

Adiabatic characteristic curves / Dynamic movements

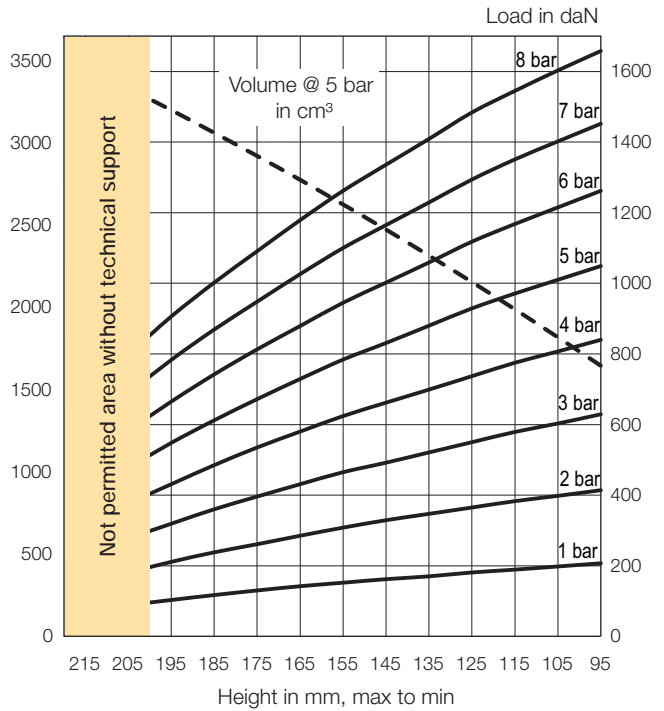
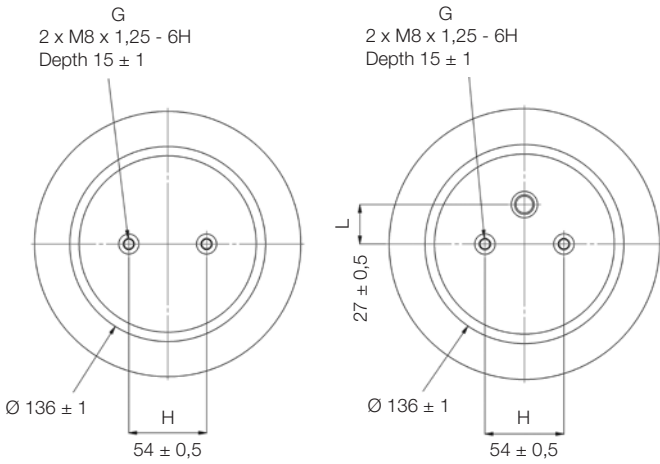

Order Code

Materials	Cups	Standard cups	Stainless steel cups
Standard temperature		KY9589	-
High temperature CR	Steel	-	-
Extreme high temp. ECO		-	-

Technical data

Air port inlet	G1/4"
Rec / Max pressure [bar]	5,5 / 8
Force to Hmin @ 0 bar [N]	30
Weight [kg]	2,00

Dimensions [mm]

Ø maxi.	200
Øe	230
H static	160
H min.	95
H max.	220
H recommended	200

Fastening torque [Nm]

G1/4"	15
M8	12



Dynamic characteristic values

Pressure p [bar]	2	4	6
Stiffness [daN/cm]	5,4	10,1	15,1
Natural frequency [Hz]	2,1	2,1	2,0
H2 rec for isolation [mm]	160		

Misalignment for H between [mm]

Axial	A = 5 mm	100 to 205
	A = 10 mm	105 to 195
Angular	Angle α = 5°	105 to 200
	Angle α = 10°	115 to 195
	Angle α = 15°	120 to 190

Static characteristic values

Pressure p [bar]	Force F [daN]						Vol. V [cm³]	
	3	4	5	6	7	8		
Height H [mm]	95	629	840	1049	1262	1452	1658	1646
	115	579	775	971	1168	1351	1545	1989
	135	521	699	880	1059	1229	1409	2316
	155	465	624	784	945	1100	1262	2627
	175	396	535	672	813	948	1091	2922
	195	319	431	548	665	783	906	3201
	205	277	376	477	582	688	798	3334

Type x Number of Convolution: **10" x 2, Ø 200**

Adiabatic characteristic curves / Dynamic movements

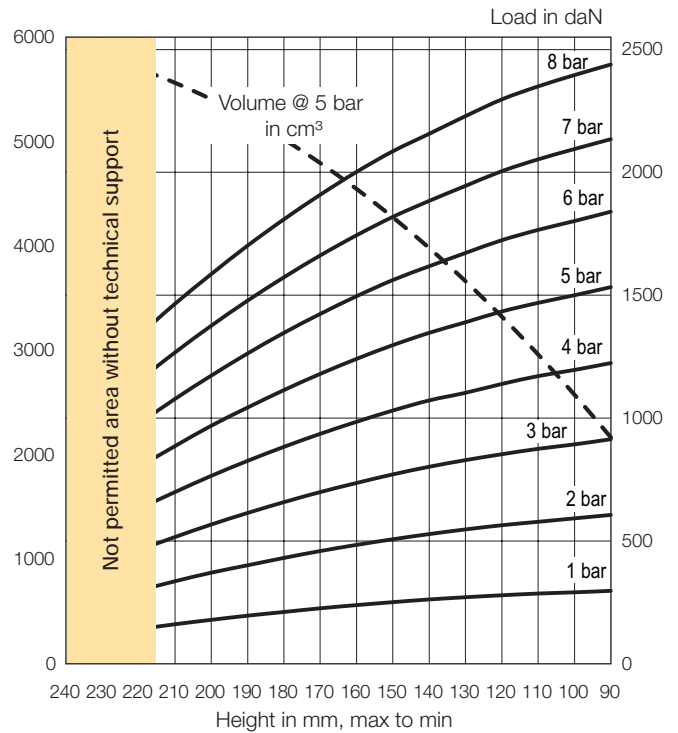
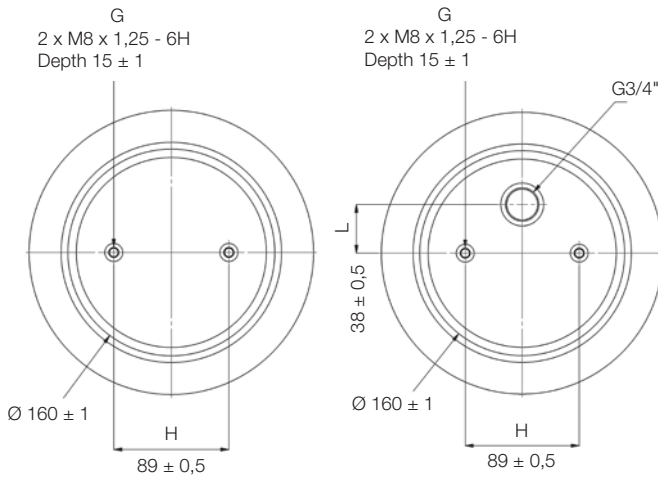

Order Code

Materials	Cups	Standard cups	Stainless steel cups
Standard temperature		KY9611	-
High temperature CR	Steel	-	-
Extreme high temp. ECO		-	-

Technical data

Air port inlet	G3/4"
Rec / Max pressure [bar]	5,5 / 8
Force to Hmin @ 0 bar [N]	60
Weight [kg]	2,70

Dimensions [mm]

Ø maxi.	240
Øe	270
H static	165
H min.	90
H max.	240
H recommended	215

Fastening torque [Nm]

G3/4"	50
M8	12



Dynamic characteristic values

Pressure p [bar]	2	4	6
Stiffness [daN/cm]	7,0	14,4	20,7
Natural frequency [Hz]	1,9	1,8	1,8
H2 rec for isolation [mm]	165		

Misalignment for H between [mm]

Axial	A = 5 mm	105 to 225
	A = 10 mm	115 to 215
Angular	Angle α = 5°	105 to 220
	Angle α = 10°	110 to 210
	Angle α = 15°	120 to 205

Static characteristic values

Pressure p [bar]	Force F [daN]							Vol. V [cm³]
	3	4	5	6	7	8		
90	914	1224	1533	1840	2135	2439	2166	
110	875	1171	1469	1766	2053	2350	2959	
130	829	1103	1390	1672	1945	2229	3661	
150	771	1031	1297	1562	1819	2086	4273	
170	699	936	1180	1424	1662	1909	4793	
210	516	699	886	1078	1267	1465	5562	
240	340	470	605	744	890	1040	5900	

Type x Number of Convolution: **13" x 2, Ø 300**

Adiabatic characteristic curves / Dynamic movements

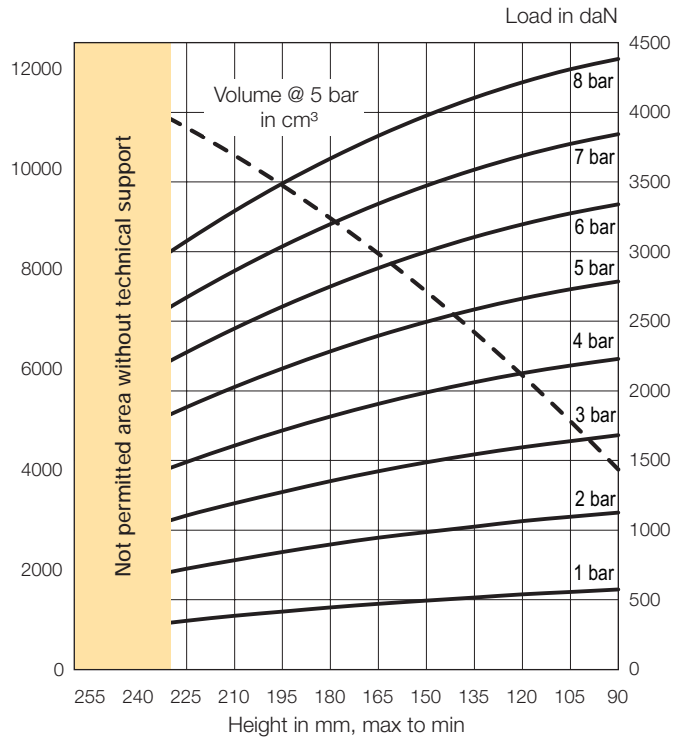
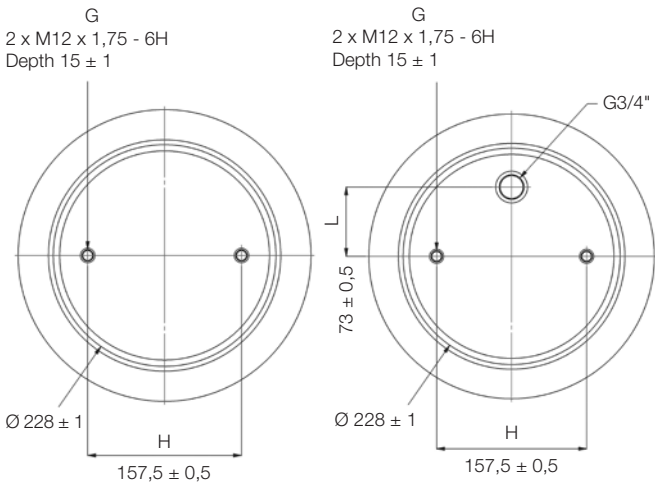

Order Code

Materials	Cups	Standard cups	Stainless steel cups
Standard temperature		KY9591	-
High temperature CR	Steel	-	-
Extreme high temp. ECO		-	-

Technical data

Air port inlet	G3/4"
Rec / Max pressure [bar]	5,5 / 8
Force to Hmin @ 0 bar [N]	100
Weight [kg]	4,60

Dimensions [mm]

Ø maxi.	310
Øe	340
H static	175
H min.	90
H max.	260
H recommended	230

Fastening torque [Nm]

G3/4"	50
M12	20

Dynamic characteristic values

Pressure p [bar]	2	4	6
Stiffness [daN/cm]	11,2	21,3	29,7
Natural frequency [Hz]	1,8	1,7	1,7
H2 rec for isolation [mm]		175	

Misalignment for H between [mm]

Axial	A = 5 mm	110 to 240
	A = 10 mm	115 to 230
Angular	Angle α = 5°	105 to 235
	Angle α = 10°	115 to 225
	Angle α = 15°	125 to 215

Static characteristic values

Pressure p [bar]	Force F [daN]						Vol. V [cm³]
	3	4	5	6	7	8	
90	1682	2230	2786	3340	3844	4384	3989
120	1595	2127	2663	3196	3689	4216	5866
150	1487	1989	2496	3000	3474	3977	7536
180	1352	1816	2284	2750	3198	3669	8999
210	1193	1607	2028	2448	2862	3292	10255
240	1000	1362	1726	2093	2464	2845	11305
260	854	1170	1495	1821	2160	2505	11891

Type x Number of Convolution: **16" x 2, Ø 350**

Adiabatic characteristic curves / Dynamic movements

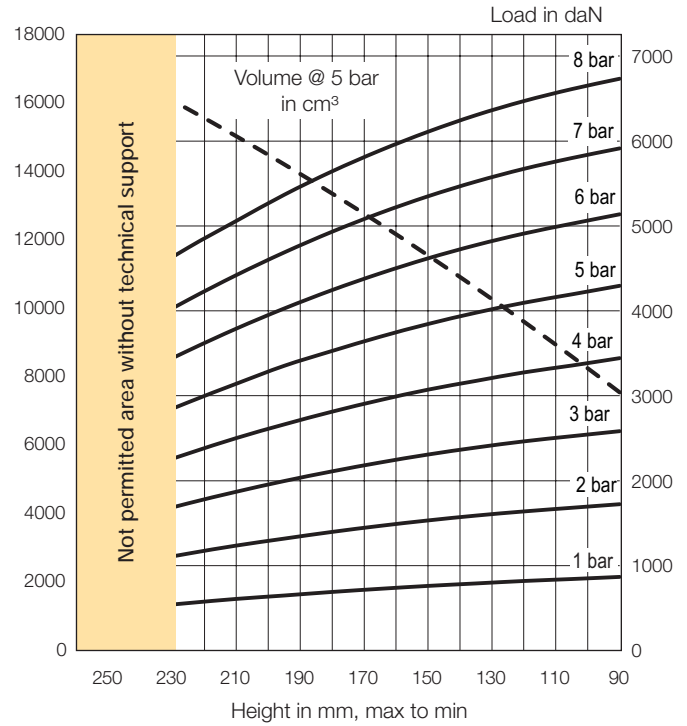
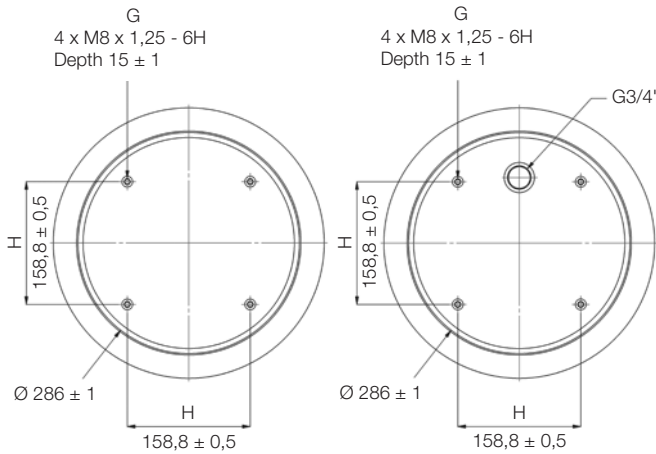

Order Code

Materials	Cups	Standard cups	Stainless steel cups
Standard temperature		KY8007	-
High temperature CR	Steel	-	-
Extreme high temp. ECO		-	-

Technical data

Air port inlet	G3/4"
Rec / Max pressure [bar]	5,5 / 8
Force to Hmin @ 0 bar [N]	100
Weight [kg]	6,20

Dimensions [mm]

Ø maxi.	370
Øe	400
H static	175
H min.	90
H max.	260
H recommended	230

Fastening torque [Nm]

G3/4"	50
M8	12

Dynamic characteristic values

Pressure p [bar]	2	4	6
Stiffness [daN/cm]	20,2	39,1	58,1
Natural frequency [Hz]	1,9	1,9	1,8
H2 rec for isolation [mm]	175		

Misalignment for H between [mm]

Axial	A = 5 mm	115 to 235
	A = 10 mm	120 to 230
Angular	Angle α = 5°	110 to 235
	Angle α = 10°	120 to 220
	Angle α = 15°	135 to 210

Static characteristic values

Pressure p [bar]	Force F [daN]						Vol. V [cm³]
	3	4	5	6	7	8	
90	2583	3443	4295	5137	5913	6733	7551
120	2463	3275	4095	4910	5672	6470	9619
150	2308	3072	3845	4618	5349	6109	11556
180	2110	2813	3528	4245	4932	5643	13363
210	1870	2502	3142	3791	4421	5059	15039
240	1584	2130	2690	3256	3817	4396	16584
260	1362	1838	2330	2834	3342	3862	17541

**Customer Application Request -
Technical Parameters**

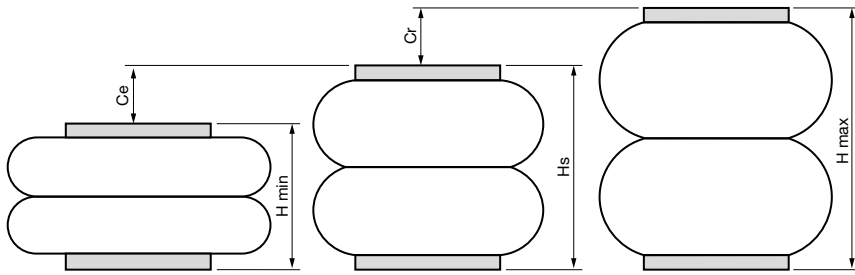

Static height (Hs): mm
 Minimum height (Hmin): mm
 Maximum height (Hmax): mm
 Rebound stroke (Cr): mm
 Compression stroke (Ce): mm

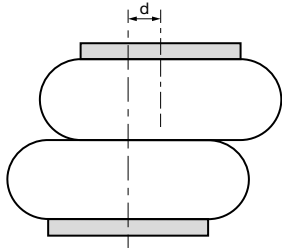

Axial misalignment (d): mm

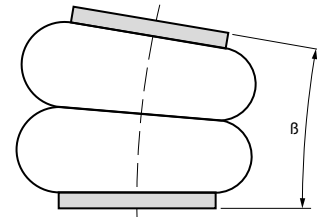

Angular misalignment, tilt angle (β): °

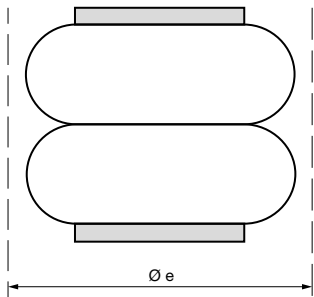

Available space (\varnothing_e): mm

Other:

Operational Parameters

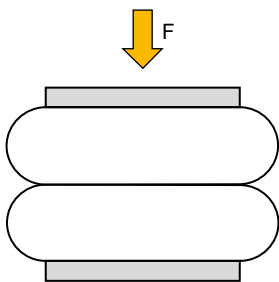

Total load (FT): daN
 Load per bellows (F): daN
 Number of bellows:

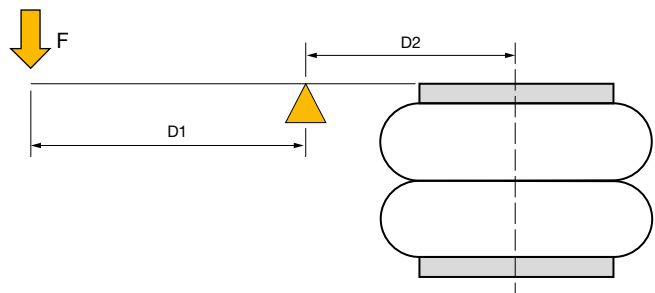

Charge (F): daN
 Distance D1: mm
 Distance D2: mm